

Operation manual

WDT11

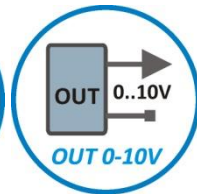

**Programmable amplifier for force sensors
with 0-10V/4-20mA output, USB and RS485 MODBUS**

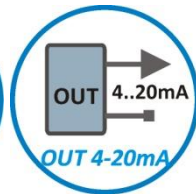
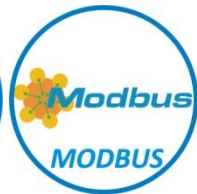

P.P.H. WObit E. J. Ober s.c.
62-045 Pniewy, Dęborzyce 16
tel. 61 22 27 422, fax. 61 22 27 439
e-mail: wobit@wobit.com.pl
www.wobit.com.pl

Translation of WDT11 operation manual

Version 2.1.2. / 12.09.2019

© P.P.H. WObit E.K.J. Ober s.c., 2019

P.P.H. WObit E. J. Ober s.c.

Dęborzyce 16

62-045 Pniewy

Polska

tel. +48 61 22 27 410

fax. +48 61 22 27 439

wobit@wobit.com.pl

www.wobit.com.pl

Thank you for selecting our product!

This operation manual will facilitate correct operation of the device.

The information contained in this manual was prepared with utmost care by our specialists, and it serve only as the product description. Based on the presented information, no conclusions should be drawn with regard to any specific features of the product or its fitness for a particular purpose.

The information does not release the user from the obligation to assess the product individuality and to test its properties and apply OSH principles. We reserve the right to change the product parameters without notice.

Please read this operation manual carefully and apply to its recommendations.



CAUTION

Any other form of use the device inconsistent with this manual is forbidden.



NOTE

For optimal and safe utilize the machine please read this operation manual carefully and keep it for future reference.

Table of contents

1. Safety and assembly rules	4
1.1. Safety rules.....	4
1.2. Mounting recommendations	4
2. Device description	5
2.1 Intended use	5
2.2 Description of connectors and diodes	6
2.3 Force sensor connection	7
2.4 Tara input / tara button	7
2.5 Analog output 4-20 mA/0-10 V.....	8
3. Device configuration	9
3.1 Connection via USB	9
3.2 Force sensor configuration	9
3.3 Configuration of 4-20 mA / 0-10 V output	10
3.4 RS485 MODBUS configuration	11
4. RS485 MODBUS communication	11
5. Complementary information	13
5.1 Force sensor types	13
5.2 Sensor measuring range	13
6. Technical parameters	14
7. Safety	15
7.1. Packaging, transportation and storage	15
7.2. Device environmental requirements.....	15
7.3. Disposal.....	15
7.4. Safety principles.....	15
8. Declaration of conformity	17

1. Safety and assembly rules

1.1. Safety rules

- Before the first use of the device please read this operation manual carefully and keep it for future reference.
- Basic instructions enabling safe operation can be found in this document.
- While using the device please apply general OSH principles for operation at industrial environment.
- Prior to first start-up of the device please make sure that all wires are correctly connected.
- Appropriate working conditions should be provided, in compliance with the device specification (e.g.: voltage supply, temperature, max. current consumption).
- Prior to any modifications of cables connections disconnect power supply.
- Usage of described device in special meaning systems (e.g. medical applications, vehicles, etc.) require use of additional safety measures against operational errors.
- This device can't be used in open space. It can cause an electric shock and shorten lifetime of the device.
- Protect the device from being penetrated by liquids or foreign bodies –can cause electric shock and/or damage of the device.
- Exceeding of recommended operational parameters can lead to damage of the device or to a fire.
- The device was designed and manufactured in a way that ensures its compliance with the principles of hazard prevention provided that the device is used in accordance with its intended use and properly maintained.
- It is forbidden any remanufacturing and modification of the device without manufacturer's permission. All non-authorized modification may cause electric shock or fire. It also results in invalid of the warranty.
- The device has warranty for 12 months. The warranty excludes mechanical and electrical damage resulting from over voltage surges, short circuits or faults and failures caused by incorrect operation by Buyer/ User. While submitting product complain it is necessary to apply complain regulations available on Manufacturer's website: <http://www.wobit.com.pl/download/regulamin-reklamacji-www20141225.pdf>.

1.2. Mounting recommendations

In environments of unknown level of interruptions it is recommended to use the following means preventing against possible interruptions of the device operation:

- Ground or zero the metal rails on which instruments are mounted,
- Do not power the device from the same line as high power devices without appropriate network filters.
- Apply power supply, sensor and signal cables screening while screen grounding should be connected only on one side as close to the device as possible.
- Avoid leading of control (signal) cables parallel or in close to power line cables.
- Avoid close vicinity of devices generating high level of electromagnetic and/or pulse interference (high power loads, loads with phase or group power regulation).

2. Device description

2.1 Intended use

The subject of this manual is WDT11- programmable amplifier for force sensors, manufactured by:



P.P.H. WObit E. J. Ober s.c.
62-045 Pniewy, Dęborzyce 16
tel. 61 22 27 422, fax. 61 22 27 439
e-mail: wobit@wobit.com.pl
www.wobit.com.pl

The WDT11 amplifier is designed for operation with load cells (4 or 6 wires without build-in electronics). It enables processing of sensor signals into current signal 4-20mA (or voltage signal 0-10 V) and digital (RS485).

Build-in RS485 interface with MODBUS protocol allows direct communication one or several modules with PLC or HMI. It is possible to connect up to 32 modules on single bus.

Module configuration is made via USB connector and special software, which allows preview of measuring values and device settings.

Features:

- Signal measurement from any load cell (4 or 6 wire)
- Result conversion into selected units
- Configurable sampling frequency (up to 120 /sec) and signal filtering
- Analog output (0)4-20 mA (or 0-10 V)
- RS485 interface with MODBUS protocol
- The USB connector for device configuration
- Build-in button and external connector for tara
- Operation status signalization via LED diodes
- Device power supply 12-24 VDC
- Mounting on DIN rail or by handles



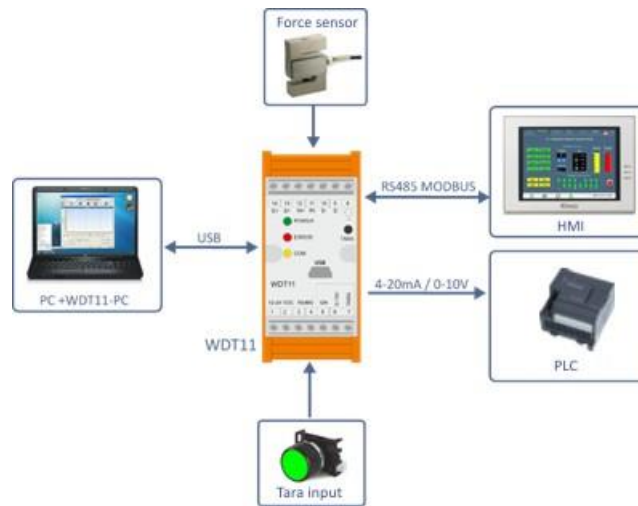
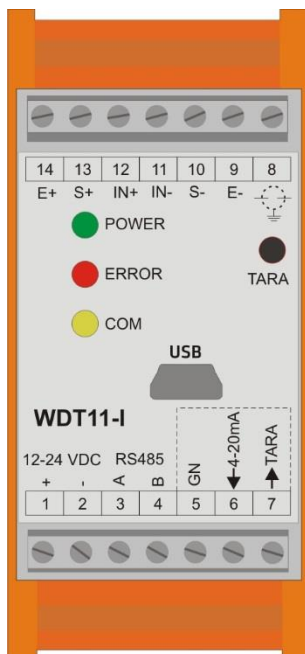

Fig. 1 The WDT11 connection possibilities.

2.2 Description of connectors and diodes



No	Description	
Power supply		
1	+	Power supply 12 -24 VDC
2	-	Power supply ground (GND)
RS485 MODBUS-RTU		
3	A	Signal +
4	B	Signal -
Analog output, tara input		
5	GND	Signal's ground (incl. power supply)
6	0-10V/4-20mA	Analog output 4-20mA / 0-10V
7	TARA	Tara input
Sensor input		
8	SH	
9	E-	Sensor power supply - (Excitation-)
10	S-	Sensing voltage - (Sense-)
11	IN-	Sensor signal - (Signal-)
12	IN+	Sensor signal + (Signal+)
13	S+	Sensing voltage + (Sense+)
14	E+	Sensor power supply + (Excitation+)

Fig. 2 Panel and connectors description.

Signaling diodes description	
	POWER – Power supply signaling
	ERROR – error signaling / exceeding range: <ul style="list-style-type: none"> ▪ Off – no errors ▪ On – device error ▪ Blinks – no sensor connection / allowable load exceeded (> 150% sensor range)
	COM – Signaling of RS485 / USB communication <ul style="list-style-type: none"> ▪ Blinks while RS485 communication

2.3 Force sensor connection

The WDT11 module can cooperate with any force sensor which has bridge with resistance bigger than 150Ω. Sensor should be connect according to scheme below.

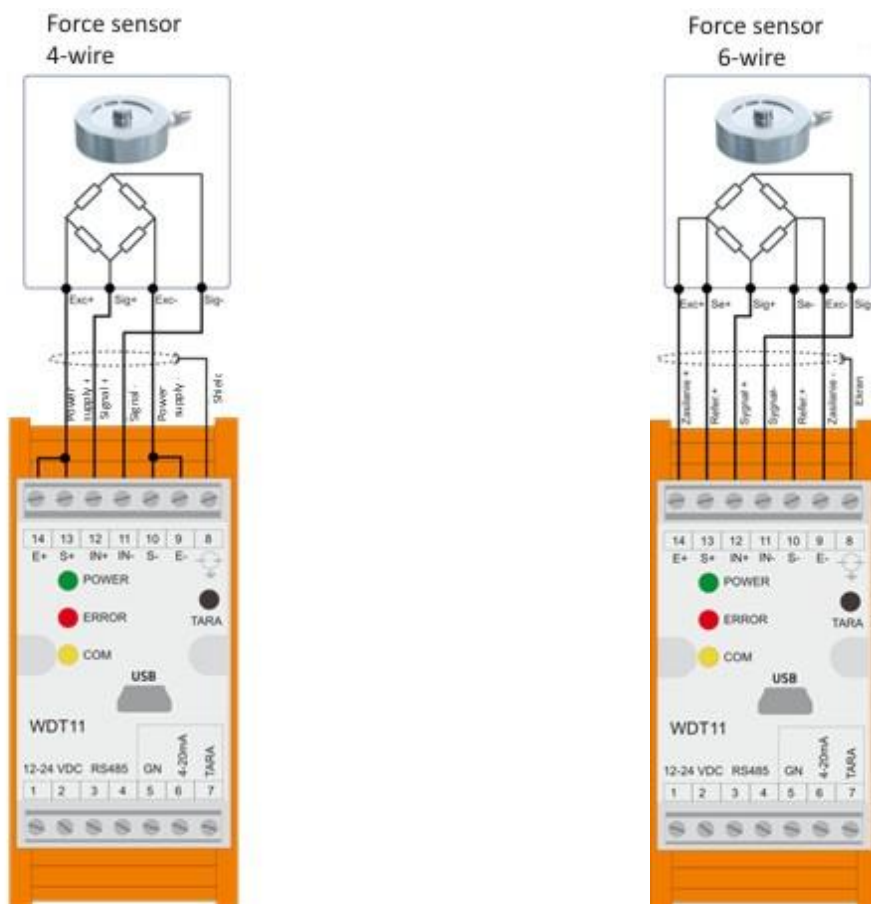

Fig. 3 Load cell connection with 4-wire and 6-wire.

To connect 4-wire sensor please clench E+ with S+ and E- with S-. Sensor cable shield should be connected to 8 terminal of WDT11.



CAUTION!

Do not clench derivation cables of sensor power supply (E+, E-) it can cause damage of the device.

Sensor type	K200, K300, K500, KB52, KB82, KMB19, KMB25, KMB31	K701, K801, K1101, K1506	K1401, K1501, K1600	KMM20, KMM30, KMM40, KMM50, KMM60, K1505, EMS70, EMS150, EMS200
Power supply + (V+)	Red	Brown	Red	White
Power supply - (V-)	Black	Yellow	Black	Brown
Power supply + (S+)	Green	Green	Brown	Yellow
Signal - (S-)	White	White	Yellow	Green

Table. 1 Wires color description for sensors from WObit's offer. CAUTION – it is possible that colors of signals may change.

2.4 Tara input / tara button

WDT1 is equipped with TARA input which tare measurement after giving voltage in range 5..24VDC (regarding to GND) during min 100 ms. To make input non active voltage should be bigger than 1 V.

Moreover on device panel is button which fulfil the same function.

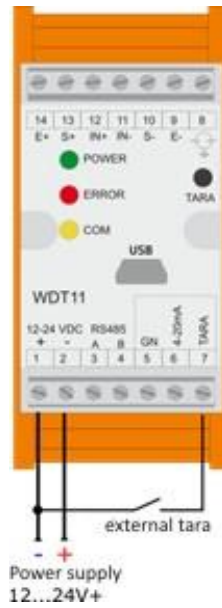

Fig. 4 Exemplary connection of external TARA input.

2.5 Analog output 4-20 mA/0-10 V

WDT11 depend on version is equipped with current output (4-20mA) or voltage output 0-10 V which process force value into proper current/voltage value. Output analog value can be calculated to measured force according to settings.

In case of module with output 4-20 mA it is possible additional signaling of device operating status:

Current value	Description
3 mA	Sensor overload (value > 1.5 x sensor range) / sensor connection error
3,9 ... 4 mA	Measurement value below range
4 ... 20 mA	Measurement within range
20 ... 24 mA	Measurement above range (> sensor range < 1.5 sensor range)

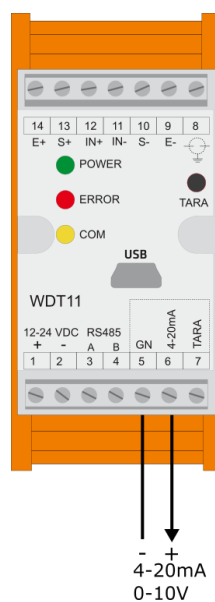

Fig. 5 Analog output (4-20 mA/0-10 V).

3. Device configuration

3.1 Connection via USB

USB connector is used for communication with WDT11-PC program. After connecting to PC and starting WDT11-PC program there should appear information about connection. Installation of USB port drivers isn't required. In case While no connection please disconnect USB wait and try to reconnect.



CAUTION!

- 1) **USB connection should be established always before turning on driver power supply.**
- 2) **USB connection is susceptible to interferences in supply network and to electromagnetic interferences which occurs in industrial conditions. While occurring problems with communication please additional protection elements like:**
 - Power line filter,
 - Good quality USB with length < 1,5m equipped with ferrite beads
 - Opt insulated USB HUBs on PC side

At higher noises can occur that communication won't be possible.



There are known problems with USB 3.0 port compatibility (blue socket) in Windows 7 while communication with USB HID devices. In case of communication problems please connect the driver to USB 2.0 port.

3.2 Force sensor configuration

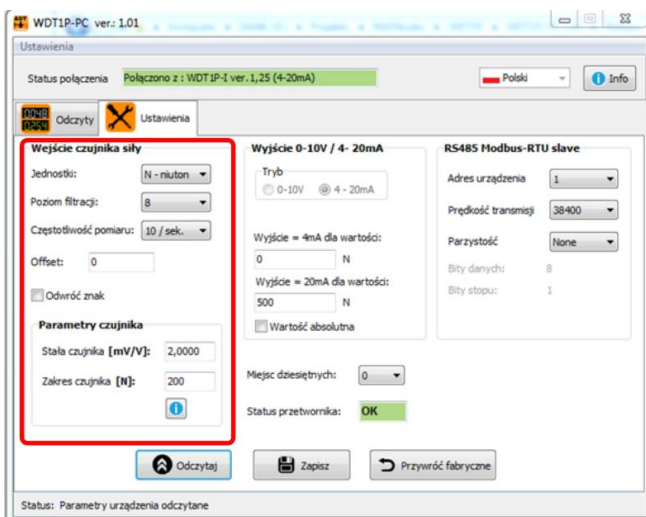

Units: it defines units of measured value.

Filtration level: it defines of constant averaging filter (quantity of further measurements which will be averaged).

Measurement frequency: it defines number of measurements made by transducer in 1 second.

Offset: it allows to set initial value for sensor.

Reverse sign: it reverse sign of measured value.

Sensor parameters:

Sensor constant [mV/V] and sensor capacity[N] – please enter values from sensor data/sensor housing.

Setting parameters of force sensor

For force sensor please enter following parameters:

Sensor capacity [N] – rated load of used sensor in N usually presented on sensor housing.

Rated output [mV/V] – sensitivity of used sensor in mV/V usually presented on sensor housing or in its documentation. At standard is value within range 1...2mV/V.

Measurement filtration

WDT11 is equipped with constant averaging filter within range 0...99 samples. Bigger filtration value increases measurements stability but cause slower response on sensor signal change.

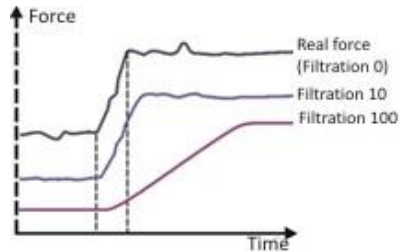

Fig. 6 Filtration influence on measurement value.

Measurement stability depend also on set measuring frequency. The most stabile measurement are obtained at high filtration value and low measuring frequency, but reaction to force change is the slowest.

$$\text{Device response time [ms]} = (\text{Filtration level} + 1) \times 1000 / \text{Measurement frequency}$$

Example:

Filtration level = 4, Frequency = 50/sec.

Device response time = $(4 + 1) \times 1000 / 50 = 100$ ms.

WDT11 will present complete value of measured force after 100ms since it starts.

3.3 Configuration of 4-20 mA / 0-10 V output

Depend on device version is available current 4-20 mA or voltage 0-10 V signal which can be freely calibrated regarding to measured force value.

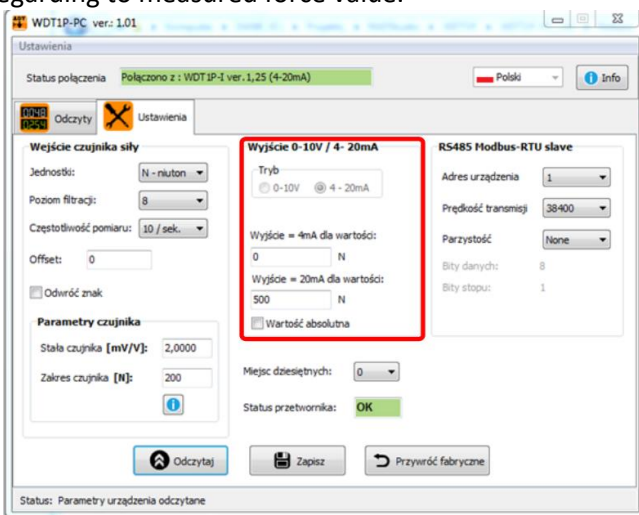

Mode: it present version of device analog output.

Output = 4 mA (0V) for value: measured force value for which on output will appear 4 mA (0V).

Output = 20 mA (10V) for value: measured force value for which on output will appear 20 mA (10V).

Total value: when marked, no matter tension or compression, analog output will generate the same value.

Example 1:

For force value within range from 0 up to 2000 analog output should change within range from 4 mA up to 20mA (force rise -> analog signal rise)

- 1) Setting **Output = 4mA for value: 0**
- 2) Setting **Output = 20mA for value: 2000**
- 3) Value saving using button **Save**

Example 2:

For force value within range from 200 up to 300 analog output should change within range from 4 mA up to 20mA (force rise -> analog signal rise)

- 1) Setting **Output = 4 mA for value: 200**
- 2) Setting **Output = 20mA for value: 300**

3) Setting saving using button **Save**

Example 2:

For force value within range 0 up to 500 analog output should change within range 20 mA do 4 mA (force rises -> analog signal fall off)

- 4) Setting **Output = 4mA for value: 500**
- 5) Setting **Output = 20mA for value: 0**
- 6) Setting saving using button **Save**

3.4 RS485 MODBUS configuration

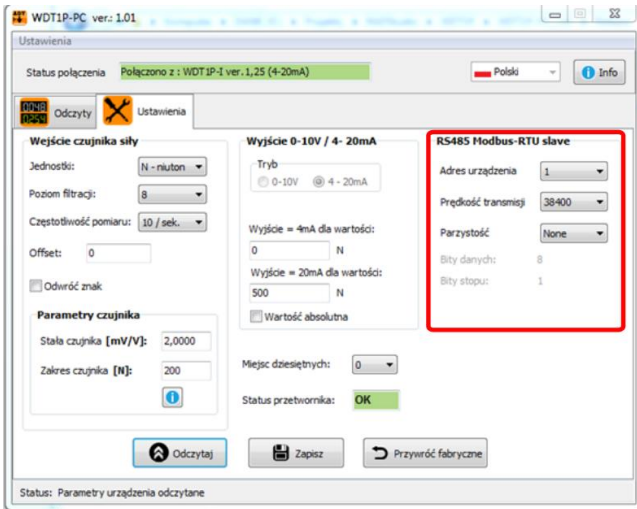

Device address: it defines slave number of WDT11 in Modbus network. Value within range 1-247.

Baud rate: please set the same as in Modbus Master device

Parity : please set the same as in Modbus Master device

4. RS485 MODBUS communication

RS485 can be used for communication with PLC, HMI or other device using MODBUS-RTU protocol. The RS485 terminal at WDT11 isn't galvanically insulated so please provide the same ground electric potential for WDT11 and master device (common GND signal).

Default baudrate parameters:

- Baudrate: **38400bps**, bits: 8, stop bit: 1, parity: none
- Slave address: **1**

Transmission speed and WDT11 address can be changed using WDT11-PC program.

Used MODBUS functions

Function no. (hex)	Description
2 (0x02)	Read input state / status
3 (0x03)	Read X registers
5 (0x05)	Record of single bit
6 (0x06)	Record of single bit
16 (0x10)	Record of N registers(for REAL numbers)



Registers map (firmware v1.01)

Address	Name	Variable type	Mode (Modbus function)	Description
Values stored in INT type registers (integer number)				
0	TENS_ACT_INT	DINT	R (0x03)	Current force value
2	TENS_MIN_INT	DINT	R (0x03)	Registered minimal force value
4	TENS_MAX_INT	DINT	R (0x03)	Registered maximal force value
6	TENS_RAW_INT	DINT	R (0x03)	Current force value without units conversion
8	TENS_SENSE_INT	DINT	R (0x03) / W(0x10)	„Rated output” in mV/V * 1000
10	TENS_RANGE_INT	DINT	R (0x03) / W(0x10)	„Capacity” parameter in N
12	TENS_RATE_INT	INT	R (0x03) / W(0x06)	Sampling frequency: 0-0, 1-10Hz, 2-33Hz, 3-50Hz, 4-66Hz,5-123Hz
13	ANALOG_INT	INT	R (0x03)	Analog output value in mA/mV *1000
Values stored in REAL type registers (floating point number)				
20	TENS_ACT_REAL	REAL	R (0x03)	Current force value
22	TENS_MIN_REAL	REAL	R (0x03)	Registered minimal force value
24	TENS_MAX_REAL	REAL	R (0x03)	Registered maximal force value
26	ANALOG_REAL	REAL	R (0x03)	Analog output value in mA/mV
28	TENS_SENSE_REAL	REAL	R (0x03) / W(0x10)	„Rated output” parameter in mV/V
Single bit values				
4000	TARA		W (0x05)	Tara
4001	MIN_MAX_RESET		W (0x05)	Reset of min/max force value
5000	INPUT_TARA		R(0x02)	Read tara input status
5001	TENS_RANGE_ERR		R(0x02)	Sensor connection error / exceeding range
5002	TENS_ADC_ERR		R(0x02)	Transducer error

R – read register, W - record

CAUTION: 4-byte number **REAL** type is contained in two registers. The first register contains younger part of the number, the second – its older part. In order to read **REAL** number value correctly, read two registers (X, X+1), and then conduct appropriate conversion.

Conversion of 2 registers (4 Byte) into 32 Bit number (REAL)

Register HI <-> Byte1

Register LO <-> Byte0

Register_X+1 HI <-> Byte3

Register_X+1 LO <-> Byte2

Number_32_bit = Byte3<<24 + Byte2<<16 + Byte1<<8 + Byte0, or **Number_32_bit = Register_2 + Register_3<<16**

Example of MODBUS communication table

Reading of measurements from ACT_INT register (Function: 03, Register address: 0)

Request (MODBUS MASTER -> ADT42)		Response (ADT42-> MODBUS MASTER)	
Device address	0x01	Device address	0x01
Function	0x03	Function	0x03
Hi register address	0x00	Number of bytes	0x04
Lo register address	0x00	Register 0x02 Hi	DINT (Byte 1)
Number of Hi registers	0x00	Register 0x02 Lo	DINT (Byte 0)
Number of Lo registers	0x02	Register 0x03 Hi	DINT (Byte 3)
CRC Hi	0xC4	Register 0x03 Lo	DINT (Byte 2)
CRC Lo	0x0B	CRC Hi	8 bit
		CRC Lo	8 bit





Tare – bit setting of TARA register (Function: 05, Register address: 4000)

Request (MODBUS MASTER -> ADT42)		Response (ADT42) -> MODBUS MASTER	
Device address	0x01	Device address	0x01
Function	0x05	Function	0x05
Hi registry address	0x0F	Hi registry address	0x0F
Lo registry address	0xA0	Lo registry address	0xA0
Register 0x00 Hi	0xFF	Register 0x00 Hi	0xFF
Register 0x00 Lo	0x00	Register 0x00 Lo	0x00
CRC HI	0x8F	CRC Hi	8 bit
CRC LO	0x0C	CRC Lo	8 bit

5. Complementary information

5.1 Force sensor types

WObit company has a broad offer of force sensors within range from single Newton's up to hundreds of kilo Newton's. Depend on assembly and way of measuring force (tension, compression) are available sensors with different shapes (table below).

Beam		For measuring tension force. Range of measured force 0..350 N. Models example: K200, K300
S-beam		For measuring large tension force. Range of measured force 0..75 kN. Models example: K1401, K1501, K1505, K1506, K1600
Round		For measuring small and large tension force. Range of measured force 0..100 kN. Przykładowe modele: KB52, KB82, KMB19, KMB25, KMB31, KMM30, KMM50, KMM60,
Round with shaft		For measuring small and large tension and compression force. Range of measured force 0..50 kN. Models example: KMM20, KMM40
Cylindrical		For measuring small and large tension and compression force. Range of measured force 0..200kN. Models example: K1101

5.2 Sensor measuring range

Rated load for sensor is a level of force which specifies top value of measuring range (value given for sensor as **bridge range (F)** in N).

Applied load is the biggest force which have unambiguous connection between force and output signal (signal value is changing linear in relation to force). Max **150%** sensor range (bridge).

Cut-off load is the biggest force which can take each sensor without it damage. It can count max. **200%** sensor range.

Destroying load means force applied to sensor shaft which exceeding can lead to mechanical damage of the sensor.

Destroying load	>200% F	Measuring range
Cut-off load	+200% F	
Applied load	+150% F	
Rated load	+100% F	
Zero load	0 [N]	
Rated load	-100% F	
Applied load	-150% F	
Cut-off load	-200% F	
Destroying load	<200% F	



CAUTION

Values above concerns only axial forces applied to the sensor. Range of forces applied non axial (a tangle to sensor measuring axis) is smaller.

Constant of e.g. KMM60 sensor is $1,5\text{mV/V} \pm 2\%$. Error of the sensor is specified by following values: tolerance of linearity 0,2% of measuring range, zero tolerance 2% of measuring range, hysteresis 0,2% of measuring range and creep measured in time of 30 minutes 0,1%. Temperature factor of zero point and constant is 0,1% of range / 10°C . Input resistance of bridge is $380\ \Omega \pm 10\%$, and output resistance is $350\ \Omega \pm 5\%$.

6. Technical parameters

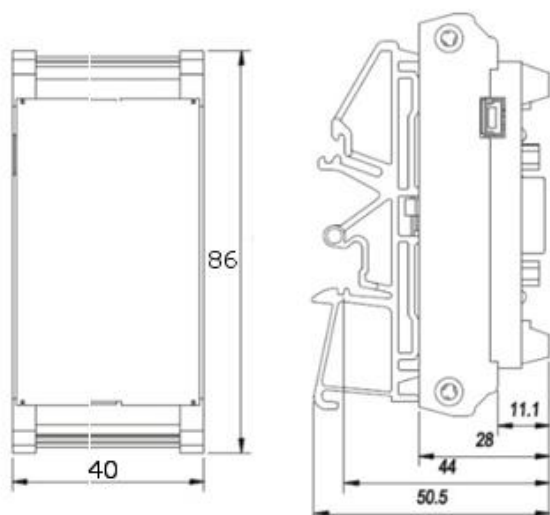

Mechanical parameters	
Housing dimensions:	40 x 86 x 50,4 mm
Weight: approx.	100 g
Temperature operating range	5..50°C
Protection degree	IP20
Mounting	Handle for DIN rail

WDT11-I - module with current output (0)4-20 mA

WDT11-U – module with voltage output 0-10 V

Electrical parameters	
Power supply	12...24 VDC , < 50mA
Force sensors inputs	<u>Sensor's power supply</u> : 5V (also 10 V sensors) <u>Max. differential voltage</u> : $\pm 39\ \text{mV}$, <u>Resolution</u> : 16 bit (0,003% FS - for typical bridge with sensitivity 2 mV/V) <u>Temperature error</u> : 0,0025%/C° <u>Measurement frequency</u> : max. 123 Hz (4, 10, 33, 50, 62, 123) <u>Time of initial annealing</u> : approx. 10 min
Analog output 0-10 V (WDT11-U version)	Mode: 0-10 V : V min = 0,02 V, V max = 10 V, max. load 20 mA Resolution: $\pm 2\text{mV}$, Accuracy 1 0mV (0,1% FS)
Analog output 0/4-20 mA (WDT11-I version)	Mode: (0)4-20 mA : I min = 3mA (sensor error) , max = 24 mA (exceeding range) Resolution: $\pm 0,008\ \text{mA}$, accuracy 0,05mA (0,1% FS)
TARA input	Low state: 0V (max. 1 V), High state: +24 V (5...24 V) Min. Pulse length >100 ms,
Communication	RS485 MODBUS-RTU , (default 38400 bps, 8:n:1, address: 1) USB : 1.1, 2.0
Operating temperature range	5..50° C
Protection degree	IP20

7. Safety

7.1. Packaging, transportation and storage

WDT11 is delivered to the user in mounted condition. The manufacturer provides proper package of the device for its transportation. Kind of the package and its durability is suited to way of transport, distance and other factors influencing on transport danger risk.

Storage of WDT11 doesn't required any specific conditions except proper storage environment. Place for WDT11 storage must provide proper protection against atmospheric conditions. It should be dry, with humidity below 70% and temperature in range 5-50°C. It is recommended to store the device in package it was delivered. To provide proper protection against humidity it is recommended to store the device on pallets or other isolating elements, not directly on the ground. Please protect the device against mechanical damages.

Before mounting the WDT11 it is necessary to unpack it. While unpacking please be careful to not to damage the device. After unpacking the device please make sure it was not damaged during transport.

Before mounting the device please read this operation manual carefully and familiarize yourself with technical drawings.



NOTE

Before starting mounting/disassembly the device please make sure it is disconnected from power supply source.

Mounting/disassembly of the device can be executed only by trained and experienced staff. They need to read this manual carefully and have finished OSH training.

7.2. Device environmental requirements

The device is not intended to use at potential explosive atmosphere. It is not recommended to use the device at atmosphere with high dust and in presence of noxious vapor.

The WDT11 temperature operating range is within 5-50°C and air humidity should be below 70%.

While selection of the machine workspace illumination please apply requirements of law principles and regulations. To provide proper illumination except its necessary strength it is important to meet basic human needs such as vision comfort, visual performance and safety. The illumination should be fitted to way of use the device.

7.3. Disposal

The device design and high quality elements provide long-time operation of the device (depend on environment conditions and way of use of the device). However changing customer' requirements, changing law principles and technology development may cause necessary of altering of the device or its disposal. It concerns also repaired or exchanged machine parts. The buyer is obligated to dispose the device or its parts in accordance with the applicable national laws, regulations and requirements.

All device parts can be recycled. Device disposal should be maintained by specialized companies.

7.4. Safety principles

For safe and optimal WDT11 utilization please carefully read, understood and follow all information and warning signs placed on the device and/or this manual.

**NOTE**

Mounting/disassembly and utilization of the device can be operated by trained Staff in range of device utilization and OSH principles.

**NOTE**

It is recommended to use the device in industrial environment.

**NOTE**

Not applying to this document may lead to health and life danger.

**NOTE**

Use the device inconsistently to recommendations at this manual may lead to its damage and invalidation the warranty.

**NOTE**

Please apply technical parameters enclosed in this document.

**NOTE**

Protect the device from being penetrated by liquids or foreign bodies. There is a risk of electric shock.

**CAUTION**

It is forbidden to extinguish any fire in device environment with water. Please use only special fire-fighting means.

**CAUTION**

It is forbidden any remanufacturing and modification of the device without manufacturer's permission. All non-authorized modification may decrease safety level and/or result in invalid of the warranty.

8. Declaration of conformity

EC DECLARATION OF CONFORMITY

No. 01/07/2016

Programmable amplifier for force sensors

P.P.H. WObit E. J. Ober s.c.
Dęboryce 16, 62-045 Pniewy

tel.: +48 61 22 27 410
fax: +48 61 22 27 439



www.wobit.com.pl

This declaration of conformity is issued at the sole liability of the manufacturer.

Name: Programmable amplifier for force sensors

Type: WDT11



The object of the declaration described above is in conformity with the relevant European Union harmonisation legislation:

- **2014/30/EU**- DIRECTIVE OF THE EUROPEAN PARLIAMENT AND OF THE COUNCIL of 26 February 2014 on the harmonisation of the laws of the Member States relating to electromagnetic compatibility replace 2004/108/WE directive,
- **PN-EN 61000-6-2:2008** - Electromagnetic Compatibility (EMC) - Durability in industrial environments,
- **PN-EN 61000-6-4:2008** - Electromagnetic Compatibility (EMC) - Emission standard in industrial environments.

Dęboryce, 12.07.2016 r.
(Place and date of issue)

Jacek Ober, Co-owner
(Name and surname, occupation)